



VERSATRAX M480

Table of Contents

About this Manual.....	5
Description	5
Certification	6
Safety.....	6
System Setup.....	10
Personnel Requirements	10
Working and Storage Environment	10
System Power	11
Power Requirements	11
Set the Line Voltage	11
Generators / Inverters.....	11
Connections	12
Pre-Configured Control Rack.....	12
Control System Connections – SD Video	13
Control System Connections – HD Video.....	13
Vehicle and Tether	15
Winch Installation	16
Portable Reel Setup	16
Mini-Reel Setup.....	17
Tether Handling.....	17
Connector Handling.....	18
Vehicle Configuration.....	19
Magnet Removal / Installation.....	19
Magnet Spacing	21
Peripheral Devices	22
Track Mounting.....	22
Track Control.....	22

Camera / Light Installation	23
Payload Calculations	24
Fall Arrest.....	25
Shipping.....	25
Operation	26
Pre-Operations Check.....	26
Post-Operations Check.....	27
ICON™ Software.....	27
Power-Up Sequence	27
Ground Fault Detection & Alarms	28
Driving the Vehicle	29
Inspection Guidelines	29
Powered Winch Operation.....	29
Vehicle Recovery	30
Troubleshooting.....	30
Camera Control Problems	30
Video Problems	31
Vehicle Problems.....	31
Winch Problems	32
Maintenance.....	32
Galvanic Corrosion Control.....	32
Rinsing and Cleaning	33
Fuse Replacement	34
Track Maintenance	34
Camera Maintenance	34
Tether Re-termination.....	34
Parts and Repairs.....	35
Ordering Parts/Customer Service	35

Warranty Repairs 35

Factory Returns to Canada..... 35

Product/System Drawing Package Availability 36

Limited Warranty Policy 36

About this Manual

This manual has been prepared to assist you in the operation and maintenance of your Eddyfi Technologies equipment. Correct and prudent operation rests with the operator who must thoroughly understand the operation, maintenance, service, and job requirements. The specifications and information in this manual are current at the time of printing.

This product is continually being updated and improved. Therefore, this manual endeavors to explain and define the functionality of the product. Furthermore, schematics or pictorials and detailed functionality may differ slightly from what is described in this manual.

Eddyfi Technologies reserves the right to change and/or amend these specifications at any time without notice.

Information in this manual does not necessarily replace specific regulations, codes, standards, or requirements of others such as government regulations.

This manual is copyright © 2023 by Eddyfi Robotics Inc. All rights reserved.

Description

The VersaTrax™ 480 is a magnetic tracked crawler capable of driving vertically or horizontally inverted along ferrous (iron based) surfaces. Additionally, the magnet modules allow the vehicle to pull longer lengths of tether than what could normally be achieved without magnets when travelling in steel pipes or on steel decks. The crawler comes equipped with a Spectrum 90™, two 901 lights and a rear facing Sapphire™ camera. The vehicle uses two tracks for motive power that are mounted underneath the main chassis plate. The vehicle utilizes two powerful rare earth magnet modules that can be manually adjusted to accommodate different pipe diameters and strength requirements.

Document: UMDU011367.docm	Revision: A10	Created by: JS	Date: 14 Nov 2023	IPN: 3063241-A10
Source Location: C:\ePDM\ISLEng\products\du-vt-m460>manuals\UMDU011367.docm				Page 5 of 36

Certification

The VT-M480 system is built in accordance with the Low Voltage Directive 2014/35/EU, Machinery Directive 2006/42/EC, and Electromagnetic Compatibility Directive 2014/30/EU.



Safety

In order to be able to use this product properly and safely, every user must first read these operating instructions and observe the safety instructions contained therein. Take care of these operating instructions and keep them in a place where they can be accessed by everyone. Untrained personnel should not handle or operate this equipment.



CAUTION: Failure to follow these safety instructions may result in injury or equipment damage.



This system includes some specific devices that have their own User Manuals. Instructions on those manuals must be also read before using the system.

WARNING: High Voltage

The tether carries 400 VDC to the rear harness block, and the Minitrac™ whips carry 400 VDC from the harness block to the tracks. Always Keep the tether capped when not installed on the vehicle. Follow the guidelines for preventing tether damage.



400 VDC can cause serious injury or death. Do not operate with a damaged tether or Minitrac™ whip. Do not operate the system with damaged wires. Damaged cabling poses a shock hazard. Repair damaged cabling before operating the vehicle. A short circuit may also damage the controller, cameras, or any attached equipment.



Disconnect the power source before servicing the product; otherwise, damage or fatal injury may result.

The power supply is equipped with a ground fault interrupt circuit. Do not cheat or bypass the ground fault interrupt circuit. Do not power the equipment from a source other than the Eddyfi Technologies provided power supply.

Document: UMDU011367.docm	Revision: A10	Created by: JS	Date: 14 Nov 2023	IPN: 3063241-A10
Source Location: C:\ePDM\ISLEng\products\du-vt-m460>manuals\UMDU011367.docm				Page 6 of 36



WARNING: Magnetic Pinch Hazard – The magnetic chassis is fitted with rare earth magnets. These magnets are very strong and create an imminent pinch hazard. Use caution when handling the magnets or vehicle near steel objects and tools, they may snap together unexpectedly.

WARNING: Medical Hazard – Operators with magnetically sensitive medical implants should be aware of and follow appropriate practices.

WARNING: Electronic Device Interference – Magnetically sensitive devices, including computer hard drives, cell phones, watches and credit cards may be disrupted or damaged by the magnetic field.

Note: Rare earth materials are mechanically weak, and magnetically very strong. They must therefore be handled very carefully to avoid damage.



Note: To reduce risk of injury and damage to equipment, always store the VT-M480 magnetic vehicle in its **magnetically shielded storage and shipping box** or store the magnets on a **steel plate** when not in use.



Note: We strongly recommend using gloves when handling the vehicle to reduce magnetic pinching hazard.



Warning: Avoid Magnetic Slamming. Extreme care must be taken when handling the vehicle, particularly when placing it onto a wall or into its storage box. Without taking heed of the sudden pull of the magnetic field onto surface, the VT-M480 can be slammed down hard causing damage to the vehicle. Using a solid grip on the vehicle, we recommend touching down the vehicle by one end first and then pivoting flat.



WARNING: Intense Optical Radiation - The Spectrum 90™ camera lights and 901 auxiliary lights are extremely bright. Never look directly at the lights. Use a welding filter (shade #8 or higher) if inspecting the LEDs.

- **CAUTION: Class II Laser:** The optional Spectrum 90™ may be equipped with laser lines. Do not intentionally stare into the beam. Typically, Class II relies on the blink reflex to limit exposure to no more than ¼-second. Intentionally staring into the beam can cause eye injury.
- When performing maintenance or functional checks of the lasers and camera lights, take precautions to protect nearby personnel from unintended exposure which could be temporarily blinding.
- Observe safe lifting practices. For storage and shipping, the VT-M480 system is packed in three parts: Controller, Vehicle, and Reel / Tether. Each of the three components is either built or packed into a Pelican case with carrying handle. The heaviest case containing the tether and mini-reel is equipped with wheels and extending handle like a suitcase.
- Do not operate the system with damaged wires. A short circuit may damage the power system, telemetry system, cameras, or attached equipment. Exposed wires may also create a shock hazard.
- Disconnect the power source before servicing the product; otherwise, damage may result.
- Although designed for durability, the vehicle and its components or attached devices may suffer structural damage if dropped or impacted. A lifeline or fall arrest system should be used at all time when the vehicle is navigating on a vertical or inverted horizontal position. In addition, stepping on the tether may pull the vehicle off the wall causing it to fall and sustain physical damage.
- All personnel operating or maintaining this equipment must be trained and competent.
- Eddyfi Technologies equipment is used in many varied environments from hot/dry to confined spaces to deep underwater. Such diverse environment risks must be addressed by the operators who are trained to work in such surroundings. As such, the operator is responsible to determine safe site setup and appropriate personal protective equipment (PPE) for operation and maintenance of the equipment.

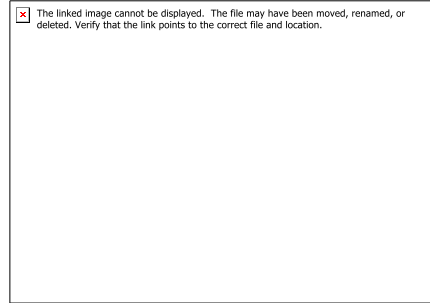

WARNING: Spark Hazard - Under no circumstances should this equipment be used in a potentially explosive atmosphere



WARNING: Trip Hazard - Never stand on the tether. A snap load to the tether may pull it out from underneath you and cause you to fall. Standing on the tether may also damage its internal conductors, cause unnecessary wear, and decrease its life. Stepping on the tether may also pull a magnetic vehicle off the wall.



WARNING: High Temperature - The camera head, auxiliary lights, and harness block may become hot during operation. Allow a cool-down period before handling.



WARNING: Mechanical Pinch Hazard – Rotating or moving components can draw fingers into a pinch position. Do not handle the vehicle while mobile parts are running, turn off power or disconnect the tether while reconfiguring or maintaining the vehicle.



WARNING: Falling Object - A lifeline or fall arrest system should be used at all times when using the magnetic option and the vehicle is navigating on a vertical or inverted surface. When the vehicle is climbing, never stand below the vehicle operations area.

System Setup

Personnel Requirements

Basic deployment of the VT-M480 system may be performed by one person. Operations at more complex worksites may require two people, especially when the console location is removed from the point of deployment.

- **Console Operator:** This person is responsible for driving the vehicle, watching the pipe and making comments about the location and pipe condition. It is also the operator's responsibility to assess whether a pipe is in the appropriate condition for safe passage of the vehicle or if there is a risk of getting stuck. The operator may also assist in general site setup (cones, warning signs, etc.), vehicle maintenance and configuration.
- **Deployment / Tether Handler / Field Maintenance:** This person has several tasks including:
 - Configuring the vehicle for the current pipe
 - Lowering the vehicle in and out of the manhole
 - Watching the tether as the vehicle enters and exits the pipe
 - Operating the reel and winding the tether during recovery

Establish a good channel of communication between the operator and deployment personnel. Good communication can avoid accidents, damage to the equipment, and promotes efficiency and productivity. In particular, the person deploying the vehicle and watching the tether must be able to quickly tell the operator to stop the vehicle if something goes wrong. The operator should never turn on power or initiate movement without first communicating with the vehicle handler.

Working and Storage Environment

The control system (interface box, power supply, and Control computer) is to be used in a **dry, covered** environment only. These components are not waterproof. Keep all cords and cables away from water.

The **tether and vehicle** are depth rated to 60 m (200 ft) of water. The tether connector is a wet-mate type which may be wet when plugged in but cannot be plugged in underwater. Keep the tether connector capped with a dummy plug when not connected to the vehicle to help keep out dirt. The tracks are tolerant to sandy and muddy conditions, although this decreases seal life. The vehicle may also be operated in dry or dusty environments.

The portable reel and winch are splash resistant only. Refer to the reel manual.

To maximize component life and minimize deployment time it is recommended that the vehicle and tether be cleaned after use and the entire system stored in a dry, dust free, location.

System **storage temperatures** are between -20 °C – 60 °C (-4 °F – 140 °F)

Document: UMDU011367.docm	Revision: A10	Created by: JS	Date: 14 Nov 2023	IPN: 3063241-A10
Source Location: C:\ePDM\ISLEng\products\du-vt-m460>manuals\UMDU011367.docm				Page 10 of 36

System Power

Power Requirements

The power requirements given below are maximums for a fully configured system with cable reel. For use with 115 VAC source, a fully configured VT-M480 system requires three independent standard 15 A circuits for power, or one 20 A and one 15 A circuits as follows.

	Power	Circuit	
Control Computer	400W	115 VAC @ 15 A	115 VAC @ 20 A
Monitor	25W		
Power Supply / Interface Box	1200W	115 VAC @ 15 A	
Powered Winch	1200W	115 VAC @ 15 A	115 VAC @ 15 A
System Total	2825 W		

Set the Line Voltage

Before powering on the VT-M480 system, it is important to check that the input voltage settings are correct - an incorrect voltage setting will damage the system power supply and the winch controller. When installing the system in a new location always check the line voltage.

- **Monitor:** Universal - no action required.
- **Computer:** Universal - no action required.
- **Interface Box:** Universal - no action required.
- **Power Supply:** Set the line voltage switch to 115/230VAC and change fuse.
 - For 115 VAC use 15 A MDA type fuse.
 - For 230 VAC use 10 A MDA type fuse.
- **Winch:** Jumpers must be set inside the hand-held controller to switch between 115 VAC and 230 VAC. Refer to the winch manual for instructions.



WARNING: Line Voltage Select – Failing to select the proper line voltage on the power supply and winch will result in equipment damage.

Generators / Inverters

If powering the system from a generator or inverter, refer to that unit's operating manual for recommendations on continuous and peak load ratings. These power sources may apply a reduced output rating based on electrical load and environmental temperature. Remember to include the power needs of other connected devices (external monitors, recording devices, lighting, etc.) when selecting a generator or inverter.

Connections

Pre-Configured Control Rack

The monitor, computer, interface box and power supply are typically installed and connected in a shock-mount portable 19 in rack case. Systems pre-configured in a control rack will only need the tether, winch and vehicle connections to be made before operations.

See the Controller and Winch / Reel user manuals for detailed operation and interconnects.

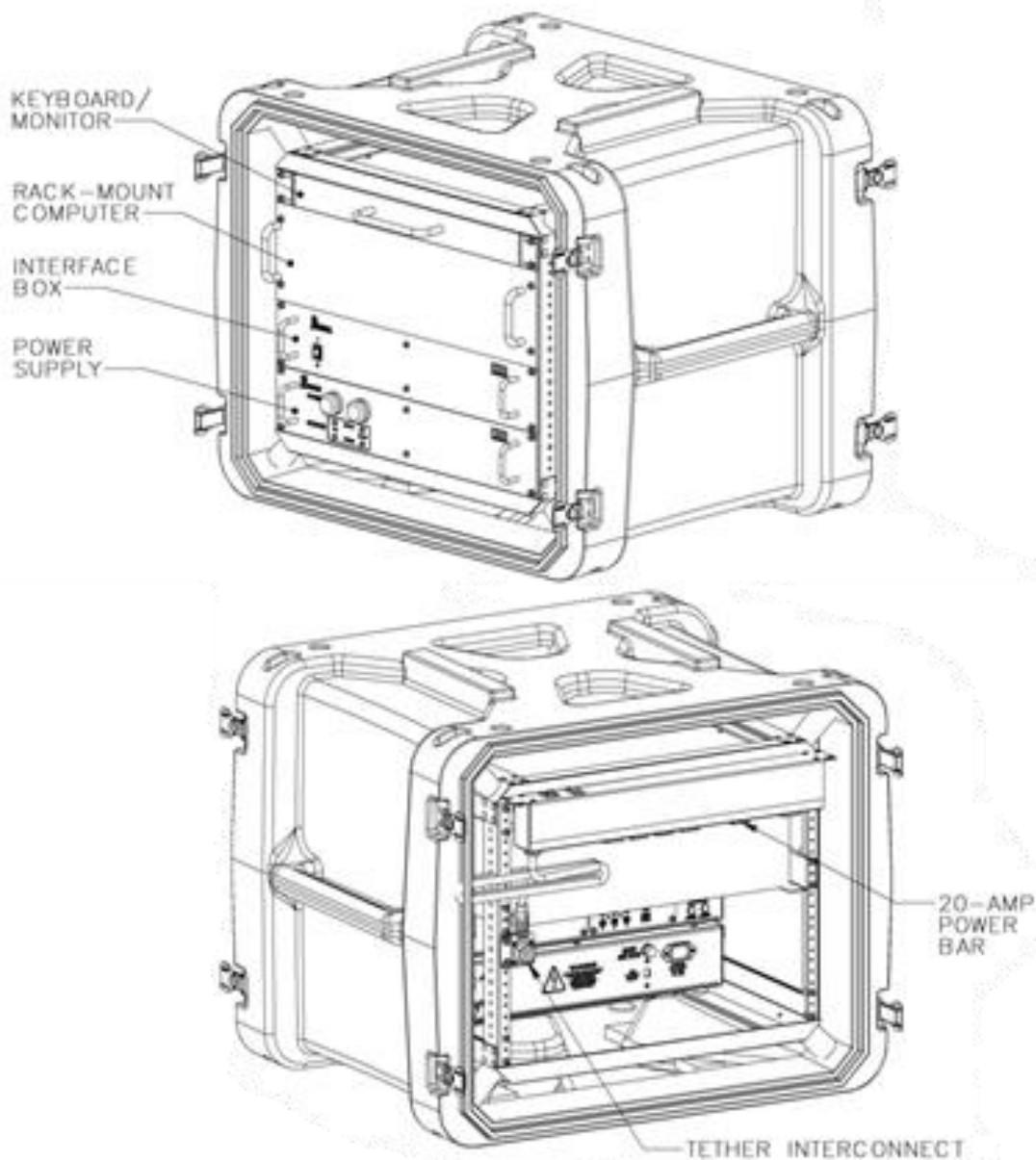

Document: UMDU011367.docm	Revision: A10	Created by: JS	Date: 14 Nov 2023	IPN: 3063241-A10
Source Location: C:\ePDM\ISLEng\products\du-vt-m460>manuals\UMDU011367.docm				Page 12 of 36

Control System Connections – SD Video

The ability to receive standard definition or high-definition video depends on the interface box used with the system. A standard definition interface box is depicted below which would be connected to the high voltage power supply.

1. Connect the power supply to the interface box using the supplied interface cable. Ensure the locking collars are screwed on all the way.
2. Connect the USB comms to the control computer.
3. Using equipment power cords connect the power supply and interface box to the 20-Amp power bar supplied with the equipment rack. Note that the power bar will only accept equipment power cords. The input cord on the power bar can be changed depending on the input voltage and location.
4. Connect the tether (or deck cable from the winch or reel) to the interface box as illustrated below.
5. Connect the front monitor or video capture to channels A, B or C (three-way splitter) and the rear monitor or video capture to channel D, E or F. These are the default output, but the connector assignments are also software configurable.

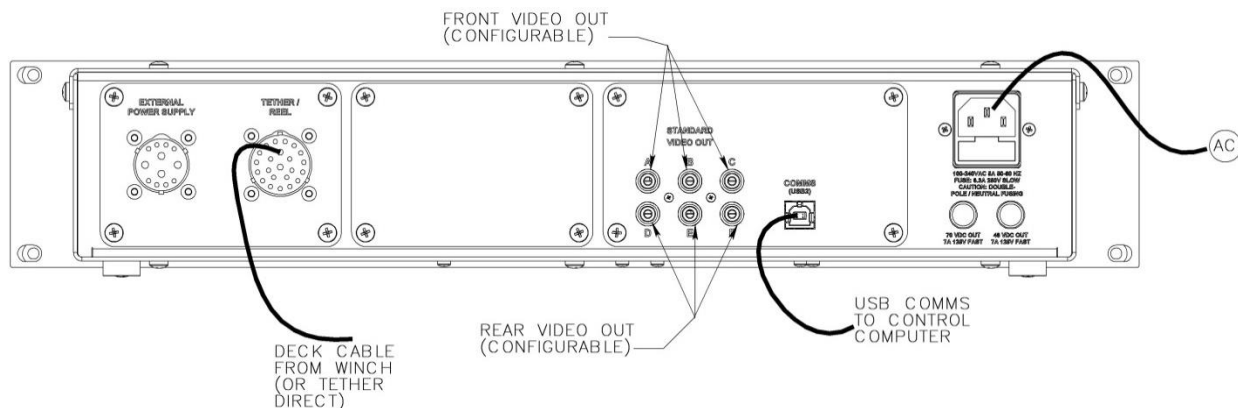

Control System Connections – HD Video

A high-definition interface box is depicted below which would be connected to the high voltage power supply. For an HD system make the following connections:

1. Connect the power supply to the interface box using the supplied interface cable. Ensure the locking collars are screwed on all the way.
2. Connect the USB2 comms to the control computer.
3. Using equipment power cords connect the power supply and interface box to the 20-Amp power bar supplied with the equipment rack. Note that the power bar will only accept equipment power cords. The input cord on the power bar can be changed depending on the input voltage and location.
4. Connect the tether (or deck cable from the winch or reel) to the interface box as illustrated below.
5. Different options may be present for SD video, depending on interface box model. If the interface box has an internal video capture card there will be two USB2 ports labelled Video A and Video B. These will be the front and rear standard definition cameras on the vehicle. Analog SD video is available as normal through the RCA connectors. Use A,B or C for front video (if this is an SD

Document: UMDU011367.docm	Revision: A10	Created by: JS	Date: 14 Nov 2023	IPN: 3063241-A10
Source Location: C:\ePDM\ISLEng\products\du-vt-m460\manuals\UMDU011367.docm				Page 13 of 36

video system) and D, E or F for rear video. There are spare front and rear video outputs which can be connected to external monitors.

- Options for HD video out include HD-SDI, USB3 (internal capture device) and component Pr-Y-Pb. These connectors are for the front High-Definition Camera. Spare connectors are active and may be connected to external monitors, capture cards or recording devices.

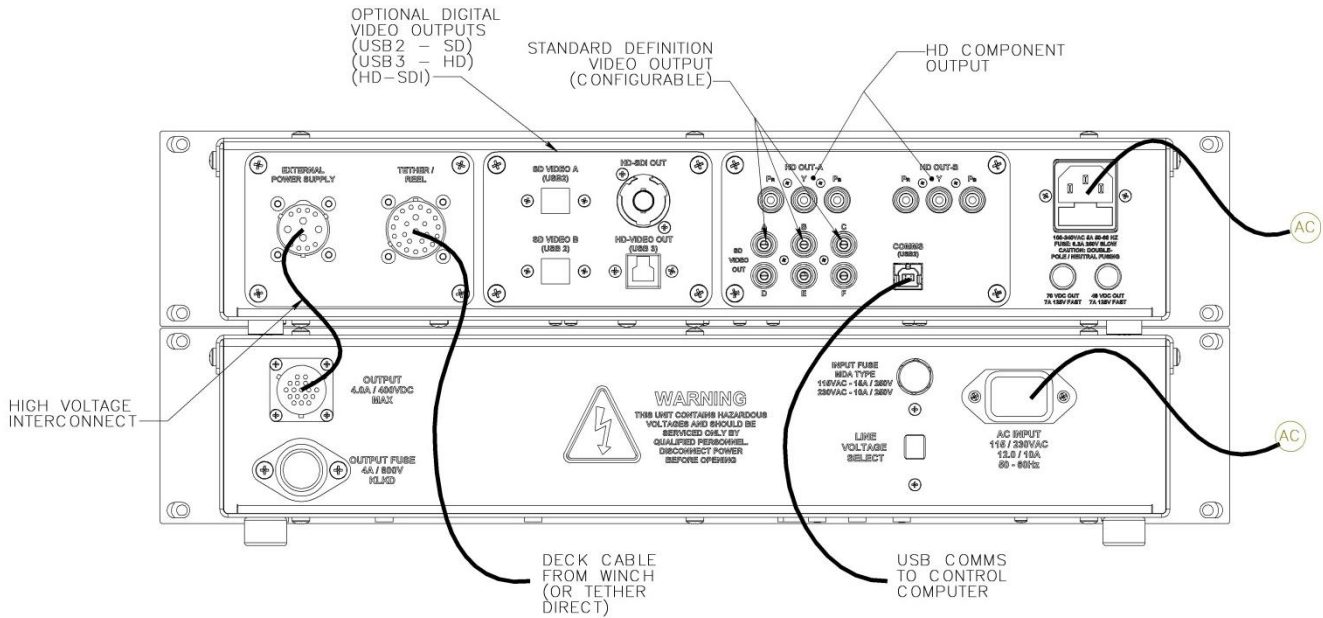

Vehicle and Tether

It is important that the tether be properly connected to the vehicle – otherwise damage to the system may result.

1. Connect the vehicle end of tether to the back of the integrated harness block. Visually line up the key in the connector before mating. Fully screw down and hand-tighten the locking collar.
2. Secure the tow cable to the cable grip on the tether using the quick link. Adjust the cable grip position to maintain a small amount of slack tether regardless the direction the tether is pulled, as illustrated below.
3. Verify all device whips from the harness block to their respective components are securely connected, and the whips are free from damage.
4. Ensure any unused connectors are capped with dummy plugs to insulate and protect their electrical contacts.

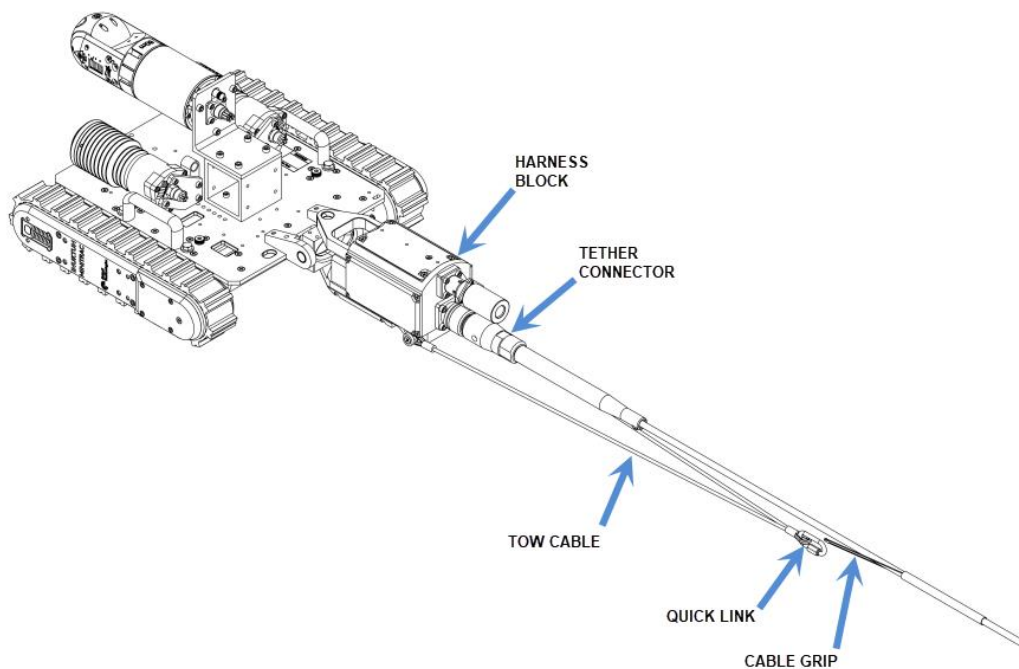

Document: UMDU011367.docm	Revision: A10	Created by: JS	Date: 14 Nov 2023	IPN: 3063241-A10
Source Location: C:\ePDM\ISLEng\products\du-vt-m460>manuals\UMDU011367.docm				Page 15 of 36

Winch Installation

If your system includes an AC powered winch refer to the winch manual for setup and installation instructions.

Portable Reel Setup

If your system includes a portable reel, follow these steps to operate:

1. Remove the shipping cap from the front of the case and insert the crank handle.
2. Connect the deck cable from the reel to the controller.
3. Disengage the packing brake (pull back and turn on the locking pin).
4. Make sure the friction brake is **engaged** - disengaging the friction brake can result in slack tether resulting in potentially jamming the reel.
5. Unwind some tether and connect the tether to the vehicle.
6. Run the tether through the level wind as follows:
 - a. There is an access slot which must be opened by lifting up on the two exposed screw heads to raise the tether support shafts.
 - b. Pull up on both sides of the axle on the top wheel and slide the tether beneath it - failing to lift up on the wheel can scuff and damage the tether.
 - c. Make sure that the two wheels that sandwich the tether top and bottom in the level wind are tracking properly as the tether is paid out - this tells the controller how much tether the reel has unwound and how far your vehicle has travelled.

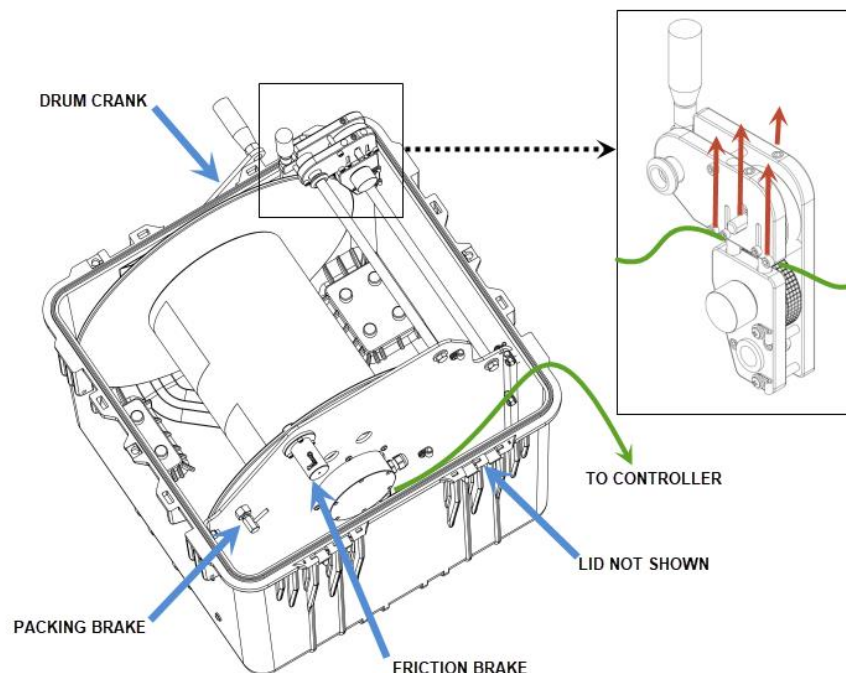

Document: UMDU011367.docm	Revision: A10	Created by: JS	Date: 14 Nov 2023	IPN: 3063241-A10
Source Location: C:\ePDM\ISLEng\products\du-vt-m460\manuals\UMDU011367.docm				Page 16 of 36

Mini-Reel Setup

If your system includes a Mini-Reel, follow these steps to operate:

1. Remove the Mini-Reel from the shipping case.
2. Connect the deck cable from the reel to the Video Interface and Power Supply.
3. Connect the encoder deck cable from the reel to the Video Interface and Power Supply (if provided with Mini-Reel).
4. **Disengage** the shipping brake.
5. Make sure the friction brake is **engaged** – disengaging the friction brake can result in slack tether resulting in potentially jamming the reel.
6. Unwind some tether and connect the tether to the vehicle.

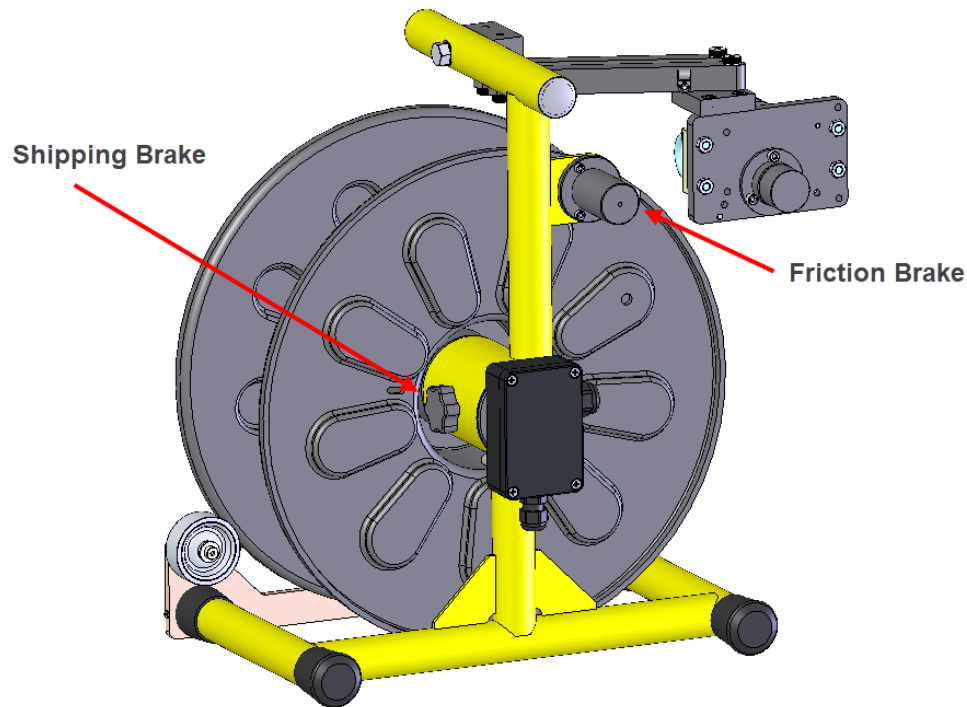

Tether Handling

The tether is one of the most important parts of the system. It feeds power and control signals to the system and returns data to the controller. If the tether is damaged from improper use, poor handling or an accident, the system may become inoperable. This could lead to significant downtime, loss of production, and avoidable costly repairs. It is encouraged to stress the importance of the tether and its use to anyone operating or maintaining the system. For maximum tether life and reliability, we recommend the following tether handling tips.

- Do not step on the tether
- Do not drive over the tether
- Do not bend the tether beyond its minimum bend radius

Document: UMDU011367.docm	Revision: A10	Created by: JS	Date: 14 Nov 2023	IPN: 3063241-A10
Source Location: C:\ePDM\ISLEng\products\du-vt-m460\manuals\UMDU011367.docm				Page 17 of 36

- Do not kink the tether
- Do not snap load the tether
- Avoid loading the tether whenever possible
- Always use the cable grip strain relief if applicable to your system
- Regularly inspect the tether for damage
- Regularly clean the tether

Note: Protecting the conductors inside the tether is critical to the life and operation of the tether. Proper tether handling and care will result in extended tether life and system reliability.

Connector Handling

Connectors are an essential part of system reliability. They should be properly maintained and cared for to ensure long life and reliability. It is recommended to follow these steps to help prevent damage and increase the life of connectors.

- Always put the cap back on the tether bulkhead when the tether is disconnected
- Always inspect the end of the connector prior to engaging
- Never plug in a dirty or damaged connector
- Visually align keyways or locating pins prior to engaging the connector
- Always fully engage or tighten the connector
- Secure locking collars finger tight
- Install dummy plugs on unused connectors
- Disconnect by pulling straight, not on an angle
- Do not pull on the cable to disengage the connector



IMPORTANT: Never “Hot Plug” any connector, this will result in internal damage to the electronics. Power down the system prior to connecting the inspection system tether.

Note: Never use WD-40 or similar solvent-based fluids on connectors or crawlers. These will cause the rubber parts of the connector or crawler to soften and swell rendering them inoperable.

SubConn Connector: Lubrication and Cleaning

- Periodically apply Molykote 111 silicone grease or equivalent before mating connectors
- For dry mate connections, a layer of grease corresponding to 1/10 the socket depth should be applied to the female connector
- After greasing, fully mate the male and female connector and remove excess grease from the connector joint
- General cleaning and removal of sand or mud on a connector should be performed using a spray-based contact cleaner like isopropyl alcohol

Document: UMDU011367.docm	Revision: A10	Created by: JS	Date: 14 Nov 2023	IPN: 3063241-A10
Source Location: C:\ePDM\ISLEng\products\du-vt-m460>manuals\UMDU011367.docm				Page 18 of 36

Vehicle Configuration

Magnet Removal / Installation

The VT-M480 comes equipped with two extremely powerful magnet modules. It is recommended that these modules remain on the vehicle to minimize handling and potential injury. If they must be removed take the following precautions:

1. Keep any sensitive electronic or magnetic devices away from the magnets
2. Work in an area away from all ferrous materials to minimize the risk of accidental magnetic adherence
3. Always store magnet modules away from each other and never bring them into contact with each other.



WARNING: Strong Magnets – Magnet modules pose a serious pinch hazard and may become permanently attached if allowed to make contact.

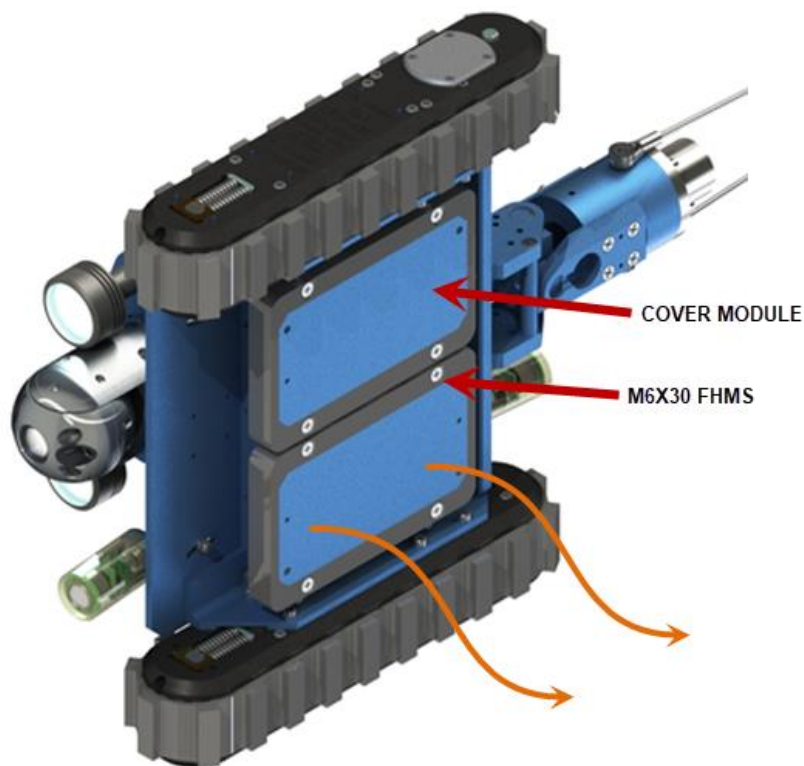

To remove the modules from the vehicle, do the following:

1. Lay the vehicle on its side; bracing may be required.
2. Cover the top magnet module with foam, wood or some other non-ferrous material at least 50 mm (2 in) thick.
3. Remove the 4x M6 x 30 mm FHMS from the bottom magnet module. **MAKE SURE TO HOLD THE MODULE INTO POSITION SO IT DOESN'T 'JUMP' ONTO THE OTHER MODULE!**
4. Very carefully slide the loose module down and away from the still attached module and store in a safe place.
5. The remaining module may now be removed.

Installation is the exact opposite of removal.

Document: UMDU011367.docm	Revision: A10	Created by: JS	Date: 14 Nov 2023	IPN: 3063241-A10
Source Location: C:\ePDM\ISLEng\products\du-vt-m460>manuals\UMDU011367.docm				Page 20 of 36

Magnet Spacing

The VT-M480 vehicle uses two very powerful permanent magnet modules to adhere the vehicle to a wall or pipe. In order to change the magnetic adhesion force, the spacing of the magnets away from the driving surface can be changed by rotating the height adjustment screws (4x M8 HEX BOLTS) by a full turn at a time, in a star pattern across the four corners.

- Tighten the screws **clockwise** to increase the height and **decrease the magnetic force**.
- Loosen the screws **counterclockwise** to decrease the height and **increase the magnetic force**.

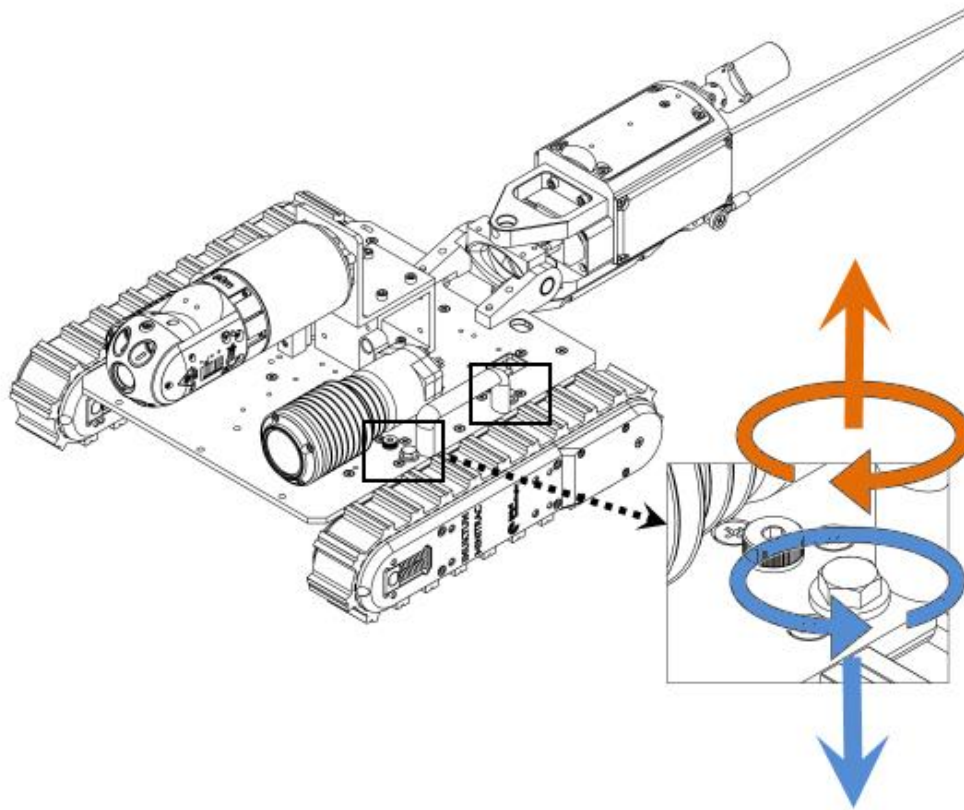

If the vehicle is being driven inside a pipe, the magnets should be lowered to account for the specific pipe diameter. All situations are unique and thorough testing should be done to make sure the vehicle will remain adhered to the wall in all situations before inspections are undertaken.

Conversely, the magnets should be raised if driving on the exterior of a pipe. Again, thorough testing for adherence is recommended prior to a full inspection.

The minimum pipe diameters for both internal and external driving is estimated at 2 m (80 in).

Document: UMDU011367.docm	Revision: A10	Created by: JS	Date: 14 Nov 2023	IPN: 3063241-A10
Source Location: C:\ePDM\ISLEng\products\du-vt-m460>manuals\UMDU011367.docm				Page 21 of 36

Peripheral Devices

Track Mounting

The VT-M480 comes equipped with two tracks. In order to remove the tracks, the magnet modules must first be removed (see Magnet Removal / Installation). Once the magnets are removed the tracks can be dis-mounted by removing 6x M6 x 16 mm SHCS from the inner mounting rails. Pull the tracks free and disconnect the track connectors.

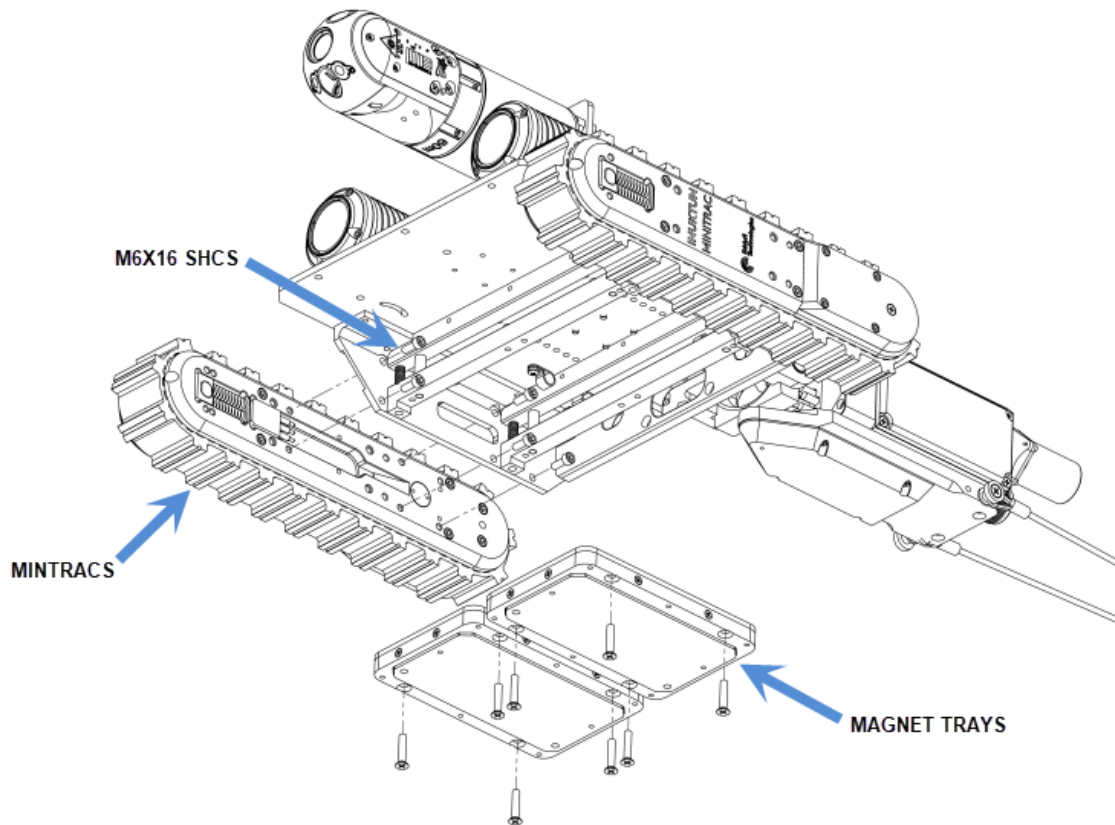

Installation of the Tracks is opposite of removal – make sure to align mating pins and lubricate the male connector.

Track Control

It is recommended to use spring replacement blocks on the tracks due to reverse tensioning of the belts during tight pivot maneuvers. See the user manual for the Tracks for more information regarding spring replacement blocks.

When the VT-M480 vehicle is operating in a vertical position, the downward force on the chassis due to the weight of the vehicle and tether may cause the tracks to back-drive and creep down the vertical

Document: UMDU011367.docm	Revision: A10	Created by: JS	Date: 14 Nov 2023	IPN: 3063241-A10
Source Location: C:\ePDM\ISLEng\products\du-vt-m460>manuals\UMDU011367.docm				Page 22 of 36

surface. Loss of power to the system will cause the tracks to quickly descend a vertical surface. The VT-M480 vehicle can be 'parked' on a vertical surface by orientating the tracks sideways instead of up/down.



WARNING: Track Creep – The tracks on the vehicle may back-drive and creep downwards while operating on a vertical surface.



WARNING: Clutched Tracks – Never use clutch tracks on a magnetic vehicle. The clutch may freewheel causing the vehicle to freely coast down the driving surface.

Camera / Light Installation

The vehicle comes standard with a forward-facing Spectrum 90™ and two 901 lights. The Spectrum camera bracket may be relocated to the indicated position by removing 4x M6 x 16 mm SHCS and reinstalling the camera to the vertical position.

To remove the lights, unfasten the 3x M5 x 12 mm SHCS and disconnect the connector.

Installation is the opposite of removal – make sure to align mating pins and lubricate the connector.

To remove the Spectrum 90™, unfasten the 3x M6 x 16 mm SHCS and disconnect the connector.

Installation is the opposite of removal – make sure to align mating pins and lubricate the connector.

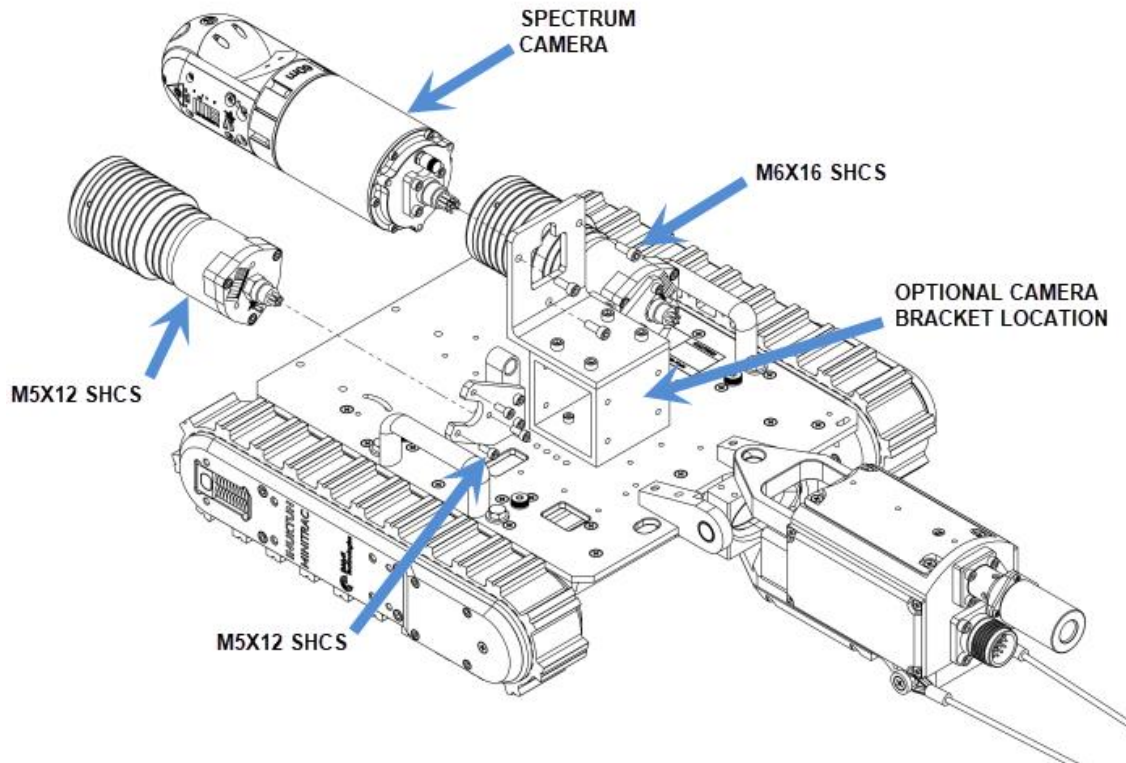

Payload Calculations

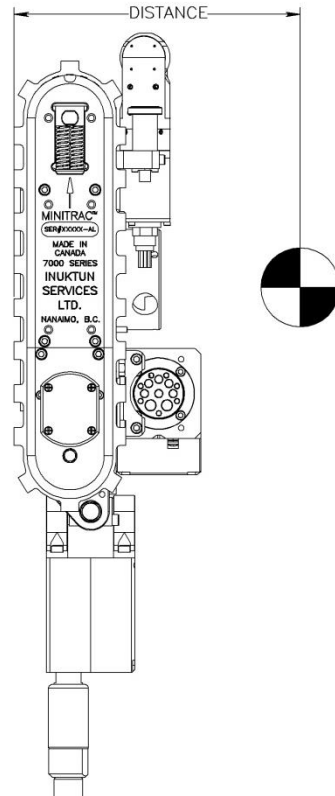

FIGURE 1: PAYLOAD CALCULATION

The maximum payload calculation is based on the magnet's ability to resist the gravitational moment (or torque) induced at the driving surface. When payload weight and/or distance from the wall is increased, the vehicle tries to pivot away from the wall and the magnets resist this moment. When the maximum payload moment is exceeded, the vehicle may fall off the driving surface during operation. The payload moment may be calculated as follows:

$$M = W \times D \leq 5.8 \text{ kg} \cdot \text{m} \text{ (500 lb} \cdot \text{in)}$$

Where W is the weight of the payload, and D is the distance of the center of gravity of the payload from the driving surface. Note that the chassis and tether weight has already been accounted for and does not have to be included in customer payload.

The above calculation is for operation on **flat surfaces**. Payload calculations are de-rated for operation on curved surfaces.

Document: UMDU011367.docm	Revision: A10	Created by: JS	Date: 14 Nov 2023	IPN: 3063241-A10
Source Location: C:\ePDM\ISLEng\products\du-vt-m460>manuals\UMDU011367.docm				Page 24 of 36

Fall Arrest

Due to the weight of the VT-M480 vehicle, the tracks will back drive and not hold the position of the vehicle during power loss or power shutdown. A lifeline or fall arrest system should be used at all time when the vehicle is navigating on a vertical or inverted horizontal position.

Attach some form of fall arrest to one or both of the lifting handles or the harness block attachment point as shown below.

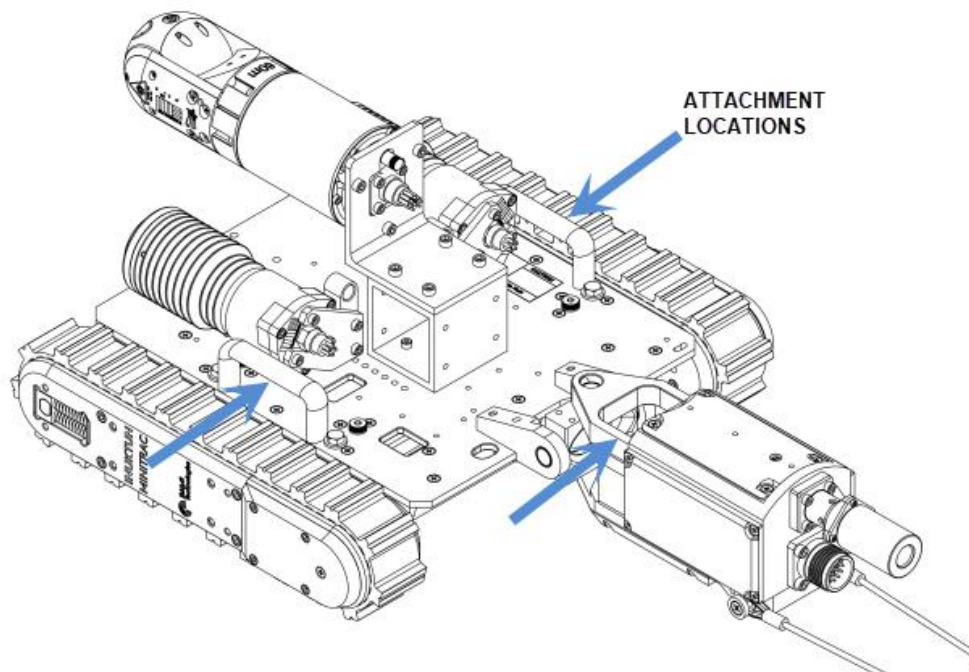

WARNING: Falling Hazard – Fall arrest system should be used during vertical or inverted horizontal operation.

Shipping

The VT-M480 vehicle uses two very powerful permanent magnet modules to adhere the vehicle to a wall or pipe. Always use a steel box to shield magnets during shipping.



WARNING: Magnetic Hazard – Always pack the vehicle in its steel shipping container to shield magnets during shipping.

Document: UMDU011367.docm	Revision: A10	Created by: JS	Date: 14 Nov 2023	IPN: 3063241-A10
Source Location: C:\ePDM\ISLEng\products\du-vt-m460>manuals\UMDU011367.docm				Page 25 of 36

Operation

Pre-Operations Check

Before each deployment of the VT-M480 system, ensure everything is completed on the following checklist.

- Check that the work area has been safely set up.
- Fall arrest is in place for vertical or inverted use.
- Check that the line voltage available at the worksite matches the equipment setup.
- Check that power and deck cable connections are correct.
- Check the vehicle for the following:
 - Check that the vehicle is in the correct configuration for the deployment.
 - Check that the magnets provide enough adhesion for the inspection geometry
 - Check the vehicle for mechanical damage to the chassis or cable harnesses which could affect its operation.
 - Ensure that all fasteners are in place and secure. In particular, check the fasteners holding on cameras, lights, tracks, and the harness block.
 - Visually inspect the vehicle and tracks to ensure that the moving parts are free of debris and functional. Make sure the track belt is free of debris and turns freely.
 - Check the tether and vehicle whips for damage.
 - Ensure camera, light, and laser ports are clean.
- Check the reel for the following:
 - Check that nothing will block movement of the level wind shuttle.
 - Check that the tether has no loose, dangling coils. Dangling coils can propagate as the drum rotates and have the potential to jump the drum. Take care of these before deploying the tether.
- Power up the system and check the following:
 - Check for sufficient SSD drive space for recording.
 - Check record directories are set.
 - Test video recording.
 - Test laser lines
 - Test auxiliary lights.
 - Test track control.
 - Test camera control.

Document: UMDU011367.docm	Revision: A10	Created by: JS	Date: 14 Nov 2023	IPN: 3063241-A10
Source Location: C:\ePDM\ISLEng\products\du-vt-m460>manuals\UMDU011367.docm				Page 26 of 36

Post-Operations Check

A Post-Ops inspection should be carried out after every deployment using the following checklist:

- Inspect the tether for damage as it is reeled in.
- Visually inspect vehicle for entrained debris or mechanical damage.
- Test each function to ensure proper operation.
- Clean the system by hosing it down with water at regular line pressure. Do not pressure wash. The tracks may be cleaned off by hosing them down while running. If the system has been used in salt water, thoroughly rinse the vehicle with fresh water right away.



CAUTION: Do not use a pressure washer to clean the camera. Very high-pressure water can push past seals and flood the camera resulting in electrical damage or personal injuries.

- Take time to pack the system properly for transport away from the worksite.
- Store the system in a dry environment.

Note: Ensuring the VT-M480 system is always stored in good working condition will minimize deployment time for future inspections.

ICON™ Software

Vehicle control, video recording and export are accomplished using ICON graphical interface controller software. The manual for ICON is integrated into the software.

- ICON Manual – Accessed through ICON or Desktop Shortcut.

Power-Up Sequence

After all wiring connections have been made, the system may be powered up. The recommended sequence for power-up is as follows:

1. Power up the control computer and allow time for it to fully boot.
2. Turn on the Vehicle Power Supply.
3. Wait 5 seconds, then switch on the Interface Box.
4. Start the ICON (Controller) control program.

Note 1: The interface box contains circuitry for auto tether tuning for best video reception. If the interface box is powered on first, the tuning circuitry may lock onto the blue screen which some imagers produce and set tuning incorrectly.

Note 2: ICON always begins with identification of attached system components (cameras, tracks, etc.). If vehicle power is turned on after ICON is started, the system will not function until ICON is closed and restarted.

Document: UMDU011367.docm	Revision: A10	Created by: JS	Date: 14 Nov 2023	IPN: 3063241-A10
Source Location: C:\ePDM\ISLEng\products\du-vt-m460>manuals\UMDU011367.docm				Page 27 of 36

Ground Fault Detection & Alarms

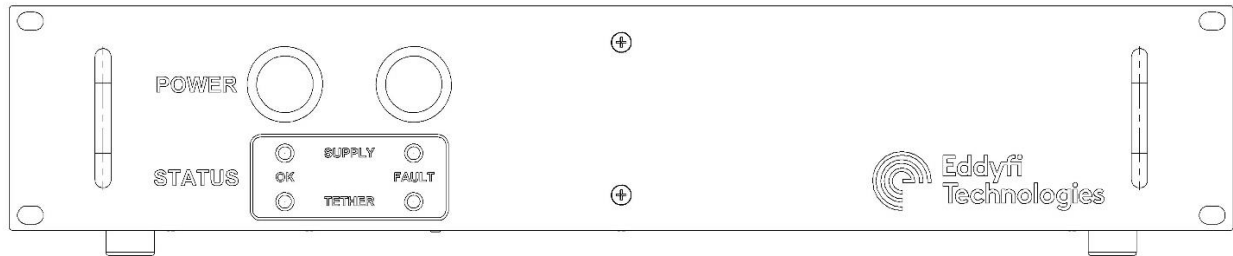

The front of the high voltage power supply includes power on and off buttons as well as status indicators. The ON button and status indicators will light green during normal operation. The two red fault indicators may light momentarily during startup and shut down; this is normal.

There are two status indicators:

1. **Supply:** This is the main power supply providing 400 VDC to the tether. A **SUPPLY** fault warning will trigger if the AC power input drops below 85 VAC or if the power supply reaches over-temperature levels. The power supply will be automatically shut down.
2. **Tether:** The power supply is also equipped with fault detection which monitors potential current leakage from the high voltage power feed to the tether and vehicle. A **TETHER** fault warning may indicate possible damage to the tether cable or water leakage inside the harness block or Minitracs™. This fault will also be triggered if the output fuse has blown due to a short circuit.

Tether faults should not be triggered under normal operation and may be an indication of a major device malfunction or a potential safety hazard. If a tether fault is announced, the power supply should be disconnected and the reel, deck cable, tether, and vehicle harness whips should be inspected for damage. If all cabling looks good, the tracks and integrated harness block should be examined.

If either of the fault indicators trip, the power supply will automatically disable power to the tether and vehicle. The corresponding status indicator will light red and the **ON** button will flash to indicate external power has been disabled. The power supply will not re-enable vehicle power until it has been reset by pushing the **OFF** button.



WARNING: A ground fault alarm may be an indication of a safety risk. The system should be turned off and carefully examined before powering back up.



Note: The GFI fault detector monitors the high voltage DC power feed only and is not a replacement for a proper GFCI protected AC power outlet.

Driving the Vehicle

When driving the vehicle, the operator should always be conscious of things that could cause the vehicle to disengage from the driving surface, either by drastically increasing magnet gap or overcoming the magnetic force entirely. These include the following:

- Welds or obstacles that are too large for the vehicle
- Inward bulges or curves that increase magnet distance
- Sheathing or coatings that increase magnet distance
- Tensioning the tether at a large angle from the driving surface (approaching perpendicularity)

Always try to minimize the above risks to avoid system damage.

Inspection Guidelines

The objective of an inspection is to obtain a recording of video and other data for review by the customer or pipe owner. If a recording is lost, fails to record, or is of poor quality the inspection will likely have to be re-done at the operator's expense. Therefore, it is in the operator's best interest to verify vehicle operation, video quality and recorder function before beginning each inspection.

A set of video overlay comments and data are usually required depending on the contract or client. Initial comments will usually include the location, pipe number and date. During the inspection the contractor may require certain pipe features or faults to be pointed out along with the distance from the pipe entry.

Conduct a complete inspection of pipe features and faults. For any feature or situation of interest, stop the vehicle and make a complete video survey using the continuous pan feature of the camera. Ultimately, the inspection is conducted for the benefit of the client who is reviewing the footage later on.

Powered Winch Operation

Refer to the winch manual for winch installation and operating instructions.

Document: UMDU011367.docm	Revision: A10	Created by: JS	Date: 14 Nov 2023	IPN: 3063241-A10
Source Location: C:\ePDM\ISLEng\products\du-vt-m460>manuals\UMDU011367.docm				Page 29 of 36

Vehicle Recovery

In the event the vehicle becomes disabled while on a mission in a pipe, provision has been made for recovery of the vehicle by pulling it out with the tether. Recovering the vehicle by pulling is a serious operation and can put great demand on the tether system. Listed below are three scenarios where the vehicle may need to be recovered. Loading the tether beyond its maximum safe capacity of 400 pounds should be considered only as a last resort.

Note: Prevention is always the best policy. When traveling through a pipe or in any unknown area, carefully watch your monitor.

The vehicle may become stuck if it is traveling through a damaged pipe section or improperly steered around a corner. If the vehicle does become stuck:

1. Determine if it is the vehicle or the tether that is stuck. Look back at the tether with the camera if possible. If the vehicle can back up but the tether will not reel in, the tether is caught on something. Try to look for and fix the cause of the catch *before* putting any more strain on the tether. The operator should use any dexterity available first to free the vehicle without resorting to force.
2. If the vehicle cannot work itself free from a snag, try using *light* tether tension and tractor power simultaneously.
3. If still stuck, try a stronger tether tension.
4. If the vehicle seems to be permanently stuck, the supervisor must decide whether to sacrifice the tether in order to pull harder, or to dig the vehicle out.

Troubleshooting

Camera Control Problems

- Not all the auxiliary lights are on.
 - The ICON software allows the lights to be controlled independently. Ensure all lights are enabled. Refer to the ICON interface manual.
 - Inspect for blown LEDs.
- Warning: High Intensity. Do not look directly into the lights. Use a welding filter (shade #8) to observe the light elements.
- Camera pan or tilt does not function in one or both directions.
 - Check that the camera is not jammed.
 - If you can hear a motor running but see no movement, there is a mechanical or clutch problem inside the camera. Contact us.
- Camera is moving very slowly.
 - Check the pan & tilt speed in the camera control window. Refer to the ICON user interface manual.

Document: UMDU011367.docm	Revision: A10	Created by: JS	Date: 14 Nov 2023	IPN: 3063241-A10
Source Location: C:\ePDM\ISLEng\products\du-vt-m460\manuals\UMDU011367.docm				Page 30 of 36

Video Problems

- No video (black or blue background)
 - Interface box is not turned on.
 - Video cables are not hooked up between interface box and computer.
 - Camera connector on vehicle is loose (turn power off first before plugging in camera).
 - Check that the camera harness whip is plugged into the correct socket on the telemetry can.
 - Check monitor input settings.
- Vehicle power is not on.
 - Check for problems with other video components between the computer and monitor.
 - Try a different monitor. Whole days have been spent on field maintenance trips only to discover a faulty monitor.
- Picture is very dark or very bright.
 - Check the light levels of both the camera and main lights.
- Intermittent picture.
 - Check and replace the video cables.
 - Check the monitor is working properly.
 - Check that the camera harness whip is fully plugged in.
 - Check for intermittent breaks in the camera harness cable.
 - Check the tether connectors at both controller and vehicle.
 - Check for tether or slip ring damage by testing tether continuity.
- Picture is blurry, will not focus, or has poor color.
 - This may be a dirty camera view port, or a narrow object lying in front of the view port.
 - Object may be too close to the camera.
- No Rear Video
 - Verify the video connection from the interface box to the computer.
 - This may be a dirty camera view port, or a narrow object lying in front of the view port.

Vehicle Problems

- Vehicle won't steer or vehicle runs backward.
 - Tracks set to the wrong positions.
 - Track reverse setting incorrect in control software.
 - Node ID conflict between one or more devices on the vehicle.
- Tracks will not run.
 - Check the track current feedback (See ICON™ manual).
 - If current is at 100% and the vehicle doesn't move, then the tracks may be jammed. They could be wedged on an object or jammed with sand. Try reversing the tracks to clear debris. If a jam won't clear you will have to recover the vehicle by pulling it out with the tether.
 - If no current registers, then power or communication is not getting to the tracks. Check all the cable connections.
 - Try power cycling the system.
 - Inspect the vehicle wiring for damage.

Document: UMDU011367.docm	Revision: A10	Created by: JS	Date: 14 Nov 2023	IPN: 3063241-A10
Source Location: C:\ePDM\ISLEng\products\du-vt-m460\manuals\UMDU011367.docm				Page 31 of 36

- Check all the system connectors.
- Try restarting ICON™
- Listen for the track motors. If the motors run but the track doesn't turn, there is a problem with the gearing or shaft pins.
- Try changing tracks. (ICON™ will require a restart.)

Winch Problems

- Tether distance does not read correctly.
 - Check that the pressure wheel is pressing the tether against the payout sheave. If the tether is being pulled up from the sheave instead of down, it may be disengaged from the sheave.
 - Check that the units are set properly in the graphical overlay.
 - Recalibrate distance encoder.
 - Ensure that the correct COM port is selected in the control software.
- Winch is very noisy.
 - The short chain directly off the motor is too tight. This chain must run with some slack. Refer to the winch manual.
- Winch does not run.
 - Check that the winch has AC power.
 - Check that the Emergency STOP button has not been pressed. (Twist to reset).
 - After a power failure the run/stop switch must be reset.
 - If there are no lights on the controller, check the fuse on the winch and in the motor control box. Refer to the winch manual.
- Intermittent problems with vehicle or camera only when the winch is running.
 - This may be caused by loose connectors.
 - Slip ring may be damaged. Pin out the tether to check continuity with the winch drum turning.

Maintenance

Galvanic Corrosion Control

Eddyfi Technologies strongly recommends cathodic protection whenever the VT-M480 is being deployed in a saltwater environment – either submerged or in salt spray, regardless of camera or track material.

Eddyfi Technologies' vehicles are designed to use **aluminum** marine anodes. Aluminum anodes are common in the marine industry and are replacing zinc anodes in many areas. For vehicle systems that are often pulled in and out of the water, aluminum anodes are especially important, as zinc anodes tend to scale over when exposed to air and may not reactivate when submerged again. An aluminum anode will always reactivate.

If the vehicle is being carried by a transport device, for example, a larger ROV, we recommend it also be protected by **aluminum** anodes or the two vehicles be electrically isolated from one another. Do not mix anode types (zinc and aluminum) on the assembly, between vehicles or between structures. There must

Document: UMDU011367.docm	Revision: A10	Created by: JS	Date: 14 Nov 2023	IPN: 3063241-A10
Source Location: C:\ePDM\ISLEng\products\du-vt-m460\manuals\UMDU011367.docm				Page 32 of 36

be only one anode type throughout. Magnesium anodes must never be used with Eddyfi Technologies equipment.

Because many of the chassis' parts are electrically isolated, the anodes provide protection by proximity rather than by direct conductive contact. Anodes are installed onto the VT-M480 as illustrated below with Loctite 243 (blue). In some cases, the Spectrum™ 90 or Spectrum™ 120 cameras may be partly equipped with anodes. Refer to the Spectrum™ 90 or Spectrum™ 120 manuals for anode placement on the Spectrum cameras. Contact your sales representative for anode replacements.

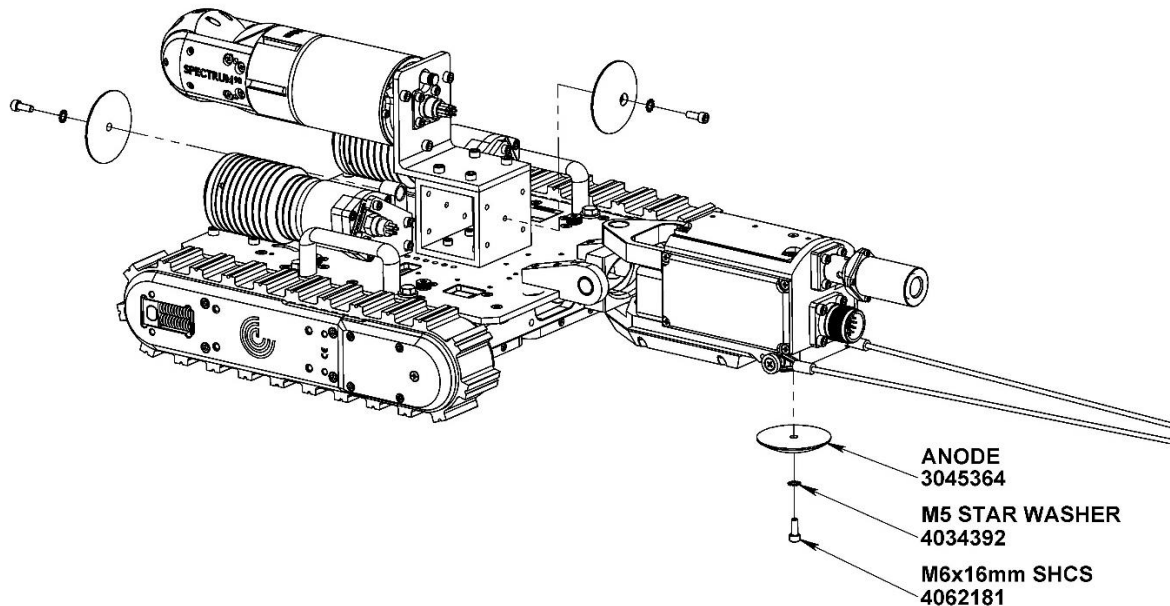

Rinsing and Cleaning

After every mission check to see if the vehicle needs cleaning.

1. If the system has been used in salt water, thoroughly rinse the vehicle with fresh water prior to being stored away. Accelerated corrosion will result if the inspection system is not rinsed properly. Pay close attention to rinsing and cleaning the camera window, LED light dome and the spaces between moving parts and track belts.
2. Use an open hose or tap at regular water line pressure for rinsing. Do not pressure wash the equipment – water will be forced into the camera at these high pressures.
3. Avoid scratching the camera port. Use glass cleaner and a soft cloth to clean the port.



CAUTION: Do not use a pressure washer to clean the camera. Very high-pressure water can push past seals and flood the components resulting in electrical damage or personal injuries.

Periodically:

1. Use a damp cloth or spray cleaner for the power supply / controller box. The box must never be sprayed down or immersed in water. Unplug the controller before cleaning.
2. For general cleaning of the cameras and tracks, use a mild detergent.

Fuse Replacement

The controller and power supply contain panel mount fuses for both AC and DC voltages. These fuses are for the safety of the operator(s) as well as to protect the equipment from damage. If a fuse blows, stop and look for possible causes. Causes might include cable damage, water incursion or improper connections. *See the controller manual for fuse replacement.*

Fuse values have been carefully selected for their application. Always replace the fuses with the same type and rating.



Caution: Disconnect the power source before checking or replacing fuses.

Track Maintenance

Refer to the Track manual for Minitrac™ maintenance and servicing instructions.

Camera Maintenance

Refer to the Spectrum 90™ or Spectrum 120HD™ manual for camera maintenance and servicing instructions.

Tether Re-termination

Tether termination is a specialized service beyond the scope of this manual. Contact Eddyfi Technologies if the tether is damaged or requires re-termination.

Document: UMDU011367.docm	Revision: A10	Created by: JS	Date: 14 Nov 2023	IPN: 3063241-A10
Source Location: C:\ePDM\ISLEng\products\du-vt-m460>manuals\UMDU011367.docm				Page 34 of 36

Parts and Repairs

Ordering Parts/Customer Service

Spare and/or replacement parts are available for your product and can be ordered directly from your local office.

When ordering parts, always make sure to quote the sales order acknowledgement (SOA) number and/or the serial number of the system component in question.

Eddyfi Robotics Inc. (Canadian Headquarters and Manufacturing Location)

2569 Kenworth Road, Suite C

Nanaimo, BC, V9T 3M4

CANADA

TF 1.877.468.5886

info@eddyfi.com

www.eddyfitechnologies.com

Eddyfi Technologies – US (American Authorized Distributor and Service Centre)

812 W 13th Street

Deer Park, TX, 77536

USA

T +1.281.542.3292

info@eddyfi.com

www.eddyfitechnologies.com

Warranty Repairs

Warranty conditions are specified in the Warranty section. Should any conditions of the manufacturer's warranty be breached, the warranty may be considered void. All returned items must be sent prepaid to Eddyfi Technologies at the above address.

Factory Returns to Canada

Some sub-assemblies of your Eddyfi Technologies product are not field-serviceable and may need to return to the factory for repair. Warranty claims must return to the factory for evaluation.

To return an item for evaluation or repair, first contact Eddyfi Technologies at our toll-free number or e-mail address. Eddyfi Technologies will supply a Return Merchandise Authorization (RMA) number with detailed shipping and customs instructions. Items shipped without an RMA number will be held at Eddyfi Technologies until the correct paperwork is completed. If cross-border shipments are not labelled as per the instructions, the items may be held by customs and issued additional fees.

All returned items must be sent prepaid unless other specific arrangements have been made.

Document: UMDU011367.docm	Revision: A10	Created by: JS	Date: 14 Nov 2023	IPN: 3063241-A10
Source Location: C:\ePDM\ISLEng\products\du-vt-m460>manuals\UMDU011367.docm				Page 35 of 36

When the product or system is being shipped anywhere by courier or shipping company, it must be packaged in the original packaging it was received in. This measure greatly reduces the consequences of rough handling and subsequent shipping damage.

Eddyfi Technologies cannot be held responsible for damages due to improper packaging. Shipping damage may have significant impact on repair turnaround times.

Product/System Drawing Package Availability

Mechanical assembly and electrical wiring diagram drawing packages for your equipment are available in PDF format upon request. Printed copies may also be purchased from Eddyfi Technologies. Contact your local sales contact for more information.

Limited Warranty Policy

Refer the Eddyfi Technologies website for warranty terms for this product.

<https://www.eddyfi.com/en/salesterms>

Document: UMDU011367.docm	Revision: A10	Created by: JS	Date: 14 Nov 2023	IPN: 3063241-A10
Source Location: C:\ePDM\ISLEng\products\du-vt-m460>manuals\UMDU011367.docm				Page 36 of 36